

## Full Length Review Article

### TRACE ELEMENTS IN HUMAN NUTRITION

\*Michael T Deans and Cantab

Flat 4, Cavendish House, Cavendish Road, Chiswick, London W4 3TD

Accepted 28<sup>th</sup> July 2015; Published Online 31<sup>st</sup> August 2015

#### ABSTRACT

A serendipitous observation, confirmed by recent reports of ice XIc, suggested ice crystallizing in liquid nitrogen is proton ordered. It undergoes a ferroelectric phase transition at 72 K, releasing latent energy as wavelength  $\lambda \sim 4\mu$  infrared laser light. Ice formed in polar regions during a primordial ice age emitted such light; polarised by multiple reflection it photophosphorylated deoxynucleotides on equatorial waters, creating chiral 'transport DNA', tDNA. F tDNAs embedded in the membranes of proto-cells charged by lightning formed H-bond lined pores. Absorbing  $\sim 4\mu$  light, they created an electric field which actively transported charged carrier-substrate complexes. A replicate tDNA signalled life's origin. I discuss nine independent metabolic pathways consistent with medical, veterinary and pharmaceutical data. In each case, trace element deficient diets disable active transport and supplements could prevent consequent mental and physical maladies. 64 tDNAs selected by 'differentiation DNAs', dDNAs, corresponding to tRNA selection by mRNAs in protein synthesis, balance cell diets. Inherited tDNAs guide the diagnosis, prevention and treatment of common maladies. 'Minions', comprising 189 anti-parallel  $\beta$ -sheet hairpin units holding nine DNA base pairs flat, evolved to pack chromosomal DNA for efficient replication. They have roles in metabolic control, their oscillating H-bond arrays account for biological clocks and serve as chips in our brains. Biological energy coupling, exemplified by sarcomeres changing shape to form  $\frac{1}{2}$ -wave resonant cavities for  $\lambda$  in striated muscle contraction, could be mimicked for nitrogen fixation. Protons accelerated along minion tunnels drive nuclear fusion; copying that might solve the current energy and pollution crisis.

Key words:

#### INTRODUCTION

In February 1967, I surmised that ice crystallizing in liquid nitrogen distorted a silica helium thermometer bulb, invoking a proton-ordered tetragonal variant of cubic ice<sup>1</sup>, to account for it, Figure 1. The crystals contract on cooling through 72 K to accommodate the irregular tetrahedral shape of water molecules. Their aligned molecular dipoles release latent energy as infrared laser light, 'ice-light' with wavelength  $\lambda \approx 4\mu$  during a ferroelectric phase transition<sup>2</sup>. Pauling's finding of residual entropy<sup>3</sup> in ice Ih at 0 K, with its H-bonds randomly oriented:

O•••H-O | O-H•••O is unchallenged.

I propose snow falling into polar pools of liquid nitrogen during an extreme primordial ice age caused it to boil, Figure 2. Water molecules carried to the surface crystallized to form tetragonal ice It. Cyclic temperature fluctuations drove its phase transition, issuing laser light. Multiple reflection by ice in clouds and on Earth's surface delivered polarized ice-light to equatorial waters. Its energy matches phosphodiester,  $P_i \sim P_i$  bonds, causing nucleotides to polymerize forming a DNA 'noodle soup'. Some formed 'transport DNAs', tDNAs, transfer RNA, tRNA analogues.

Figure 3 shows the H-bond lined 'hole' through a tRNA. Ice-light, replaced by adenylyl cyclase hydrolysing ATP in modern life, depolarises those H-bonds. Figure 4 illustrates the ratchet mechanism propelling charged trace element-substrate complexes through a unit membrane.

---

\*Corresponding author: Michael T Deans,  
Flat 4, Cavendish House, Cavendish Road, Chiswick, London W4 3TD.

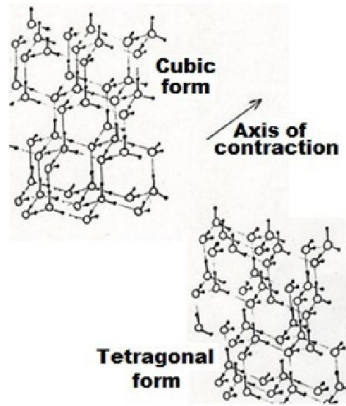

W1 Fig. 1. Ordering transition

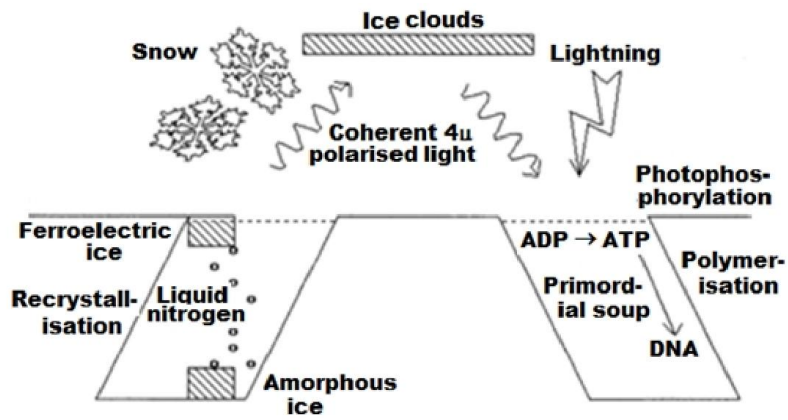

W2 Fig 2. Ice-light makes DNA for origin of life



W3 Fig. 3. tRNA<sup>4</sup> showing hole

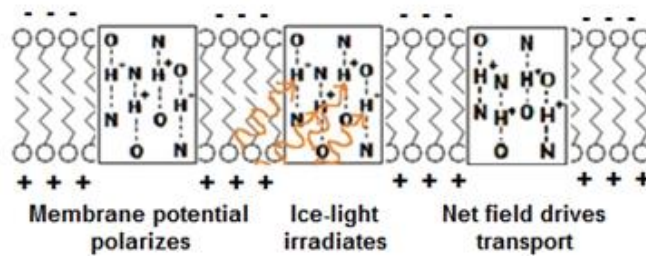

W4 Fig. 4. tDNA pumping needs membrane potential, ice-light & complex recognition

Their requirements determine life's atomic alphabet and a molecular vocabulary of carrier-substrate complexes with roles underlying all biological systems, Figure 5.

H																			He
Li	Be											B	C	N	O	F		Ne	
Na	Mg											Al	Si	P	S	Cl		Ar	
K	Ca	Sc	Ti	V	Cr	Mn	Fe	Co	Ni	Cu	Zn	Ga	Ge	As	Se	Br		Kr	
Rb	Sr	Y	Zr	Nb	Mo	Tc	Ru	Rh	Pd	Ag	Cd	In	Sn	Sb	Te	I		Xe	
Cs	Ba	La	Hf	Ta	W	Re	Os	Ir	Pt	Au	Hg	Tl	Pb	Bi	Po	At		Rn	
Fr	Rh	Ac	Rf	Db	Sg	Bh	Hs	Mt	Ds	Rg	Cn								
				Ess	Tox	n/u													

W5 Fig 5. Periodic table of the elements showing essential, toxic and unused elements

Trace element nutrition

There are nine mutually independent, mathematically orthogonal chemical systems, minion symmetry<sup>5</sup> dictates their number. Their associated properties are listed in Table 1.

#	SYSTEM	TISSUE	CARRIER	SUBSTRATE	PATHOLOGY
1	motility	muscle	Ca <sup>++</sup>   Mg <sup>++</sup>	SO <sub>3</sub> <sup>=</sup>	spasticity
2	sensitivity	nerve	Na <sup>+</sup>   K <sup>+</sup>	catecholamines	depression
3	excretion	kidney	Mn <sup>++</sup>	salt	kidney failure
4	respiration	lung	I <sup>-</sup>	O <sub>2</sub> .H <sub>2</sub> O	bipolar
5	metabolism	liver	Cu <sup>++</sup>	amino-acids	growth defects
6	rigidity	bone	SiF <sub>6</sub> <sup>=</sup>   AlF <sub>6</sub> <sup>=</sup>	apatite	Alzheimer's
7	assimilation	gut	Zn <sup>++</sup>	β-Dglucose	diabetes
8	reproduction	gonads	Ag <sup>+</sup> & arginine	pyrophosphate	cancer
9	water-pumping	heart	Mn <sup>++</sup> & SeO <sub>3</sub> <sup>=</sup>	water	heart disease

W6 Table 1. Nine independent biological pathways

Motility

Vitamin A's isomers retinal or retinol depend on pH, retinal's (-C=C=C-)n bonds conduct energy as solitons<sup>6</sup>, Figure 6, converting sulphur from glutathione to sulphite, SO<sub>3</sub><sup>=</sup>.

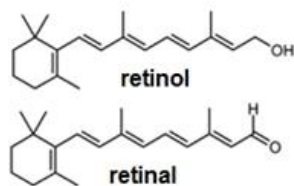

W7 Fig 6. Retinol and retinal

Sulphite and selenite, SeO<sub>3</sub><sup>=</sup> exchange magnesium, Mg and manganese, Mn for calcium, Ca respectively, Figure 7. Mg catalyzes hydrolysis of ATP, releasing P<sub>i</sub> ~ P<sub>i</sub> bond energy as photons, replacing life's original energy source, ice-light. In striated muscle, ~1/2λ sarcomeres contracting to resonate with these photons converts chemical to mechanical energy.

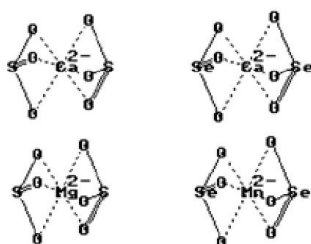

W8 Fig 7. SO<sub>3</sub><sup>=</sup> and SeO<sub>3</sub><sup>=</sup> exchange ions

Silver, Ag exchanges creatine for creatinine phosphate, Figure 8 (similar to phospho-mevalonate transporting water, see *Water pumping*). For sustained muscle contraction, creatine phosphate replenishes ATP.

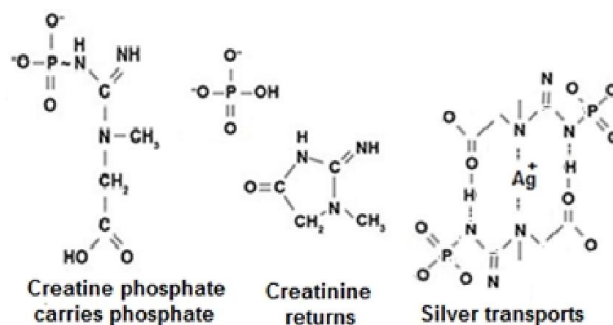

W9 Fig 8. Creatine and creatinine exchange with silver as carrier

### Sensitivity

Nerve transmission transmits pain, catecholamines exchange sodium, Na and potassium, K at synapses. Na<sup>+</sup> ions have the same shape and size as H<sub>2</sub>O, slowing cell chemistry by making the cell sap viscous by forming hydrates possibly as large as Na<sup>+</sup>.28H<sub>2</sub>O. K<sup>+</sup> binds less water, speeding reactions.

Cell charge and metabolic rate change when catecholamine rings swap three Na<sup>+</sup> for two K<sup>+</sup> ions, accounting for the 'fight or flight' reaction<sup>7</sup>, Figure 9.

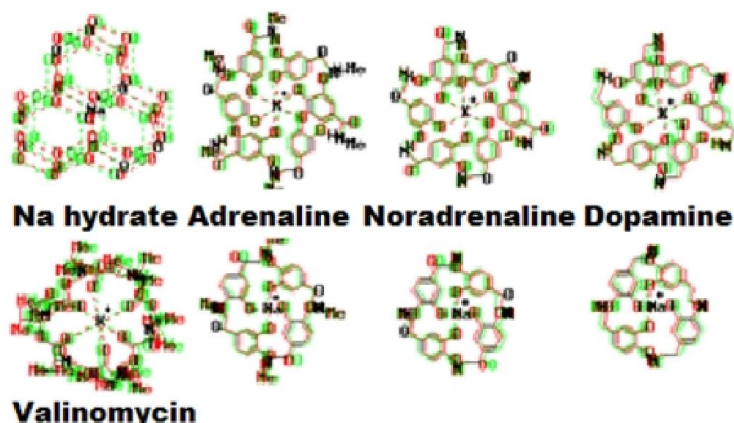

W10 Fig 9. Catecholamines form 4- and 6-member rings round Na<sup>+</sup> and K<sup>+</sup> mimicked by valinomycin

Substituting codeine or morphine creates larger complexes, blocking tDNA pumps and preventing pain transmission. Pain sensitivity increases when more pumps are enrolled to compensate, leading to drug addiction, Figure 10.

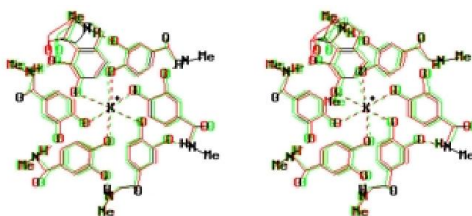

W11 Fig 10. Morphine and codeine form larger rings, blocking tDNA.

### Excretion

Aldosterone, angiotensin, rennin, histamine and aspirin<sup>8</sup> control salt excretion. Complexes with Mn chlorides: MnCl<sub>3</sub><sup>-</sup>, MnCl<sub>4</sub><sup>-</sup> and MnCl<sub>6</sub><sup>4-</sup>, act as carriers. Zn-dependent carbonic anhydrase catalyzes exchange of bicarbonate, HCO<sub>3</sub><sup>-</sup> for Cl<sup>-</sup>, the 'chloride shift'. Carbon dioxide, CO<sub>2</sub> excretion controls pH:

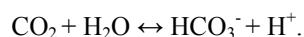

**Respiration**

Breathing exchanges oxygen, O<sub>2</sub> for carbon dioxide, CO<sub>2</sub>, it's then bound to iron in erythrocyte haemoglobin for distribution. Thyroid glands load iodine, I into thyroxine. It releases iodonium, I<sup>+</sup> carrier for oxygen hydrate, O<sub>2</sub>.H<sub>2</sub>O at target tissues, Figure 11. The purple and yellow colours of littoral seaweeds match those of I<sup>+</sup> and I<sup>-</sup>, this system protects them from tidal oxygen concentration changes.

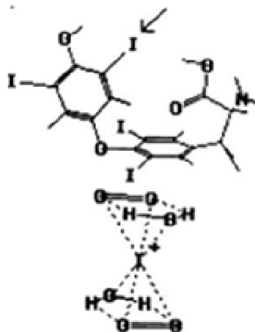

W12 Fig 11. Thyroxine delivers iodine, H<sup>+</sup> displaces I<sup>+</sup>

tDNAs accelerate protons, bonding nitrogen, oxygen and nitric oxide to nicotinamide, active component of NAD, Figure 12. Bacteria fix nitrogen more efficiently than the Haber process<sup>9</sup>. A parallel reaction, equivalent to the photolysis of water, accounts for atmospheric oxygen. Another releases nitric oxide, controlling [vasodilation](#). Both cyanide and carbon monoxide block this tDNA.

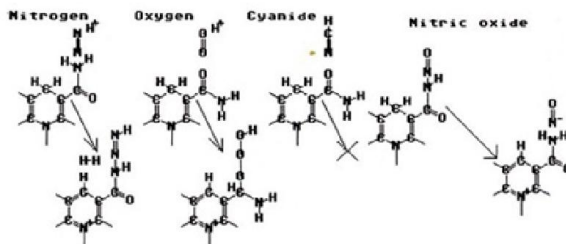

W13 Fig 12. Proton transport explains nitrogen fixation, oxygen release, cyanide poisoning and nitric oxide activation

Iodine deficiency causes swollen thyroids, goitre. Iodide accumulating in the eyes causes exophthalmos. Mutant tDNAs disrupt nerve cell oxygenation, causing bipolar disorder. Mania and depression correspond to excess and deficient oxygen. Lithium, Li, diagonally related to iodine in the periodic table, is used to manage the condition.

**Growth**

Copper, Cu carries amino acids, *c.f.* Biuret test. The hypothalamus instructs the anterior pituitary gland to issue growth hormones. They deliver Cu to endocrine glands and tissues and promote hormone and protein synthesis, Figure 13. Transfer RNAs pump amino acids to ribosomes through the endoplasmic reticulum membrane during protein synthesis using the same mechanism as tDNAs. Failure causes gigantism, dwarfism and other growth defects such as acromegaly. Cu accumulating in the eye leads to Wilson's disease. Cu supplements and bracelets are promoted for treating arthritis.

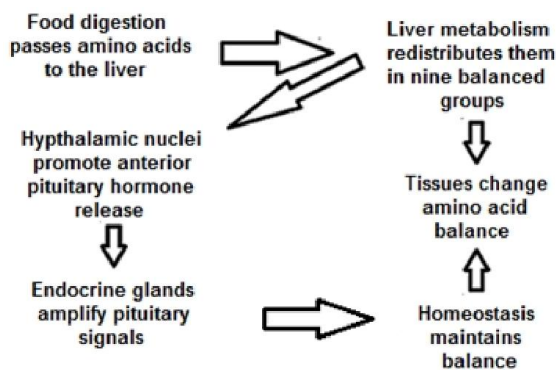

W14 Fig 13. Cu mediates hormone and protein synthesis

A full complement of ‘differentiation DNAs’, dDNAs enables stem cells to acquire all substrates and participate in all aspects of metabolism. Gastrulation and blastulation during development effectively starve cells of nutrients. Their dDNA bound tDNAs ‘overheat’ and switch from substrate transport driven by adenyl cyclase to protein synthesis using guanyl cyclase, creating ‘hook’ proteins binding tissue cells together, Figure 14.

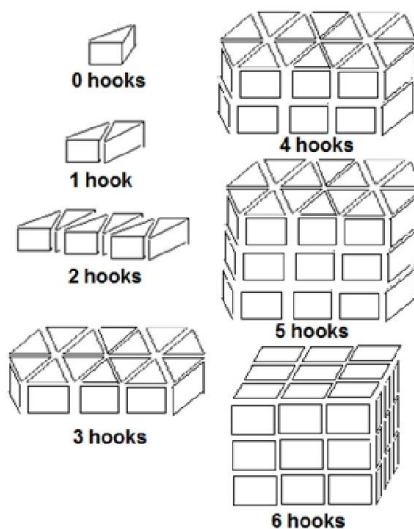

W15 Fig14. Hook proteins define tissue morphology

After differentiating in this way, the nutrient balance causes tissues to adopt specialist functions. Up to five differentiation steps are sustainable, creating all natural morphologies, Table 2. Should a sixth level arise, amorphous neoplasms, tumours and cancers can result. Immune system 1-hook leucocytes normally counter their proliferation. As Alexander Pope warned, *A little knowledge is a dangerous thing*, biotechnologists creating synthetic tDNAs could create monsters.

HOOKS	MORPHOLOGY
0	Undifferentiated ‘pluripototent’ stem cells
1	Eggs, sperm and immune system leukocytes
2	Spirogyra filaments
3	Sponge sheets
4	Bi-layered worms
5	Liver and other organs use combinations of up to 5 hooks
6	6-hooked cells, allowing tumour and cancer growth

W16 Table 2. Hooks determine morphology

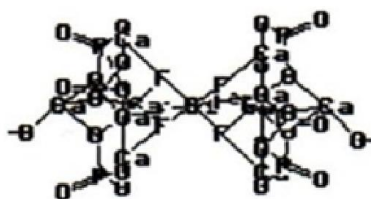

W17 Fig 15. SiF<sub>6</sub><sup>2-</sup>.apatite complex

**Rigidity**

Calcium has a strong affinity for fluorine, illustrated by the stability of flourspar, CaF<sub>2</sub>. Silicon hexafluoride, SiF<sub>6</sub><sup>2-</sup> is carrier for calcium phosphate as found in the minerals apatite, Ca<sub>10</sub>(PO<sub>4</sub>)<sub>6</sub>(OH)<sub>2</sub>, Figure 15 and its cousin fluorapatite, Ca<sub>10</sub>(PO<sub>4</sub>)<sub>6</sub>(F)<sub>2</sub>. The parathyroid gland may have coevolved with the adjacent thyroid glands — both incorporate halides to hormones. Parathyroid hormone, PTH is continuously secreted, preventing F<sup>-</sup> accumulating in these glands. Vitamin D stores ~265 nm UV sunlight, matching the energy needed to make Si~F bonds, Figure 16.



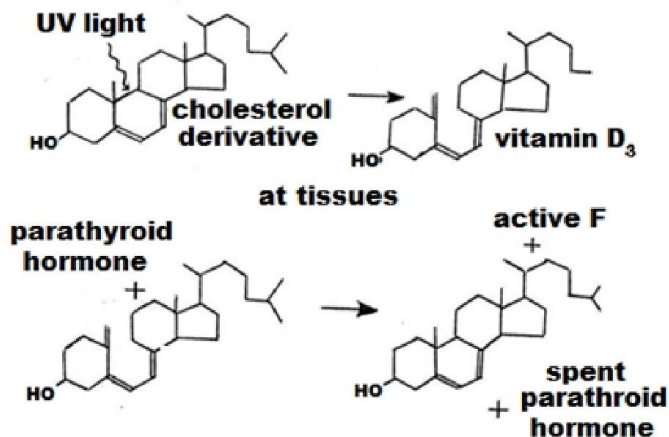

W18 Fig. 16. UV light energises vitamin D for silicon hexafluoride synthesis at low pH

Figure 17 shows how skeletal maintenance is controlled. As for *Motility*, retinal transfers energy as solitons from vitamin D to form Si~F bonds, then SiF<sub>6</sub><sup>-</sup> carries apatite. SiF<sub>6</sub><sup>-</sup> assembly is pH-sensitive, in kidney failure and at menopause, acidity can cause osteoporosis. Plants use the same substrate-carrier complex to form their silica, SiO<sub>2</sub> hard parts, inhibited when acid air pollution (SO<sub>x</sub> and NO<sub>x</sub>) entering via stomata prevents SiO<sub>2</sub> production, causing leaf-fall<sup>10</sup>. Since liming the soil proved ineffective, regulating diesel exhaust has been sidelined.

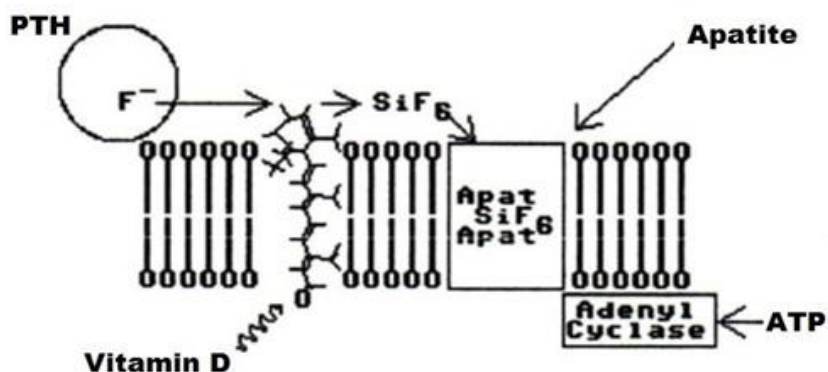

W19 Fig 17. PTH delivers F<sup>-</sup> and vit A transfers solitons from vit D, synthesising apatite carrier SiF<sub>6</sub><sup>-</sup> for skeletal maintenance

Acid air pollution and tobacco smoke acidify the cavity behind the nose, promoting inappropriate SiF<sub>6</sub><sup>-</sup> synthesis. It can pass along the olfactory nerves to the brain, where its breakdown releases F<sup>-</sup>, causing Alzheimer’s Disease<sup>11</sup>. Fluoride disrupts protein folding (probably occurring as nascent proteins are fed through tDNAs), creating tangled proteins. If mutant tRNAs misinterpret mRNA sequences, the wrong amino acids are incorporated to some proteins, yielding similar tangles. This explains prion diseases<sup>12</sup>, mutant tRNAs embedded in these proteins render them infectious agents.

Vitamin D deficiency in infancy causes rickets, corrected by cod liver oil, UV lamps or sunlight. F<sup>-</sup> replacing OH<sup>-</sup> in apatite hardens tooth enamel, justifying fluoridation of water supplies to counter childhood tooth decay. Tea drinking typically supplies adequate F<sup>-</sup>. Excessive exposure causes tooth mottling. Fluorinated anaesthetics promote enzyme synthesis to metabolise them. F<sup>-</sup> is excreted as aluminium hexafluoride, AlF<sub>6</sub><sup>-</sup> four days later and F<sup>-</sup> is simultaneously cleared from the brain. Dementia symptoms are temporarily relieved until more of the toxic halide is released as nerve cells disintegrate. Eliminating acid air pollution or devising pharmaceuticals having the same effect might prevent or treat dementia.

**Assimilation**

When we, like Pavlov’s dog, anticipate, taste or smell food, pancreatic β-cells secrete insulin. The hormone circulates zinc, Zn, carrier for β<sub>D</sub>glucose, Figure 18. Glucose transport mediates carbohydrate metabolism throughout the biosphere, keeping sugar concentrations in animal blood and plant xylem and phloem steady. The liver stores it as glycogen, leaves as starch and its conversion to fat causes obesity.

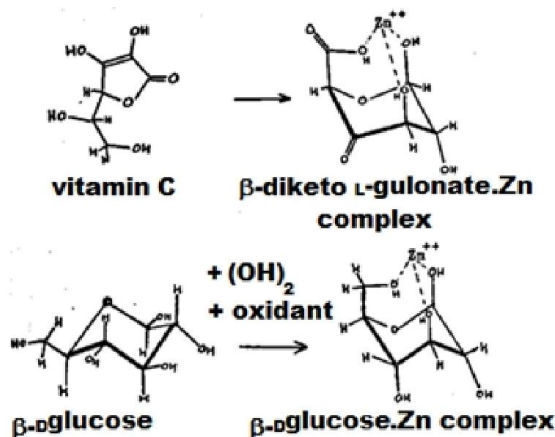

W20 Fig 18. Vitamin C derivative L-gulonate and beta-D-glucose bind zinc

Glucagon, secreted by pancreatic  $\alpha$ -cells, recycles Zn, disabling glucose transport. Both hormones exhibit the ‘triangle of sweetness’<sup>13</sup> also found in vitamin C derivative L-gulonate, taking Zn to places insulin can’t reach. Zn incorporates hydroxy-proline to connective tissue protein collagen. Vitamin C/Zn Deficiency caused scurvy, affecting the skin, digits and gonads of ancient mariners, until limes high in vitamin C prevented it. Calamine™ lotion, active ingredient Zn sulphide, works the same way.

Banting and Best won the Nobel Prize for discovering insulin and Dorothy Hodgkin<sup>14</sup> another for determining its structure. Defective glucose transport causes diabetes, sufferers may go blind if Zn accumulates in the vitreous humour of their eyes and they often have kidney and foot problems. An implanted Zn monitor might improve management.

Zn regulates appetites for food and sex, appetizing oysters and caviar encourage snacking and increase libido. Anorexia, bulimia and other eating disorders respond to Zn supplements. Cu coil contraceptives prevent sperm reaching their target by inhibiting their glucose uptake. Adult haemoglobin replacing the foetal version releases bilirubin, Zn adds glucose for excretion preventing neonatal jaundice, if bilirubin reaches the brain, seizures ensue. Normally treatment is exposure to blue light, Zn from colostrum<sup>15</sup> or sucking a midwife’s pewter spoon are equally effective.

Supplementary Zn and vitamin C<sup>16</sup> blocking tDNAs prevent rhinoviruses causing colds and flu entering nasal cells. Binge drinking diverts Zn to the liver for detoxification by Zn-dependent alcohol dehydrogenase. Less Zn numbs the brain, explaining inebriety and suggesting ways to manage alcoholism. Combining barbiturates with alcohol can be lethal, they act the same way.

Beryllium, lead and indium mimic Zn. The Victorians used beryllium as a poison, calling it ‘glucinium’ for its sweet taste. Ancient Romans died after using lead acetate as a sweetener. Endocrine glands may exchange indium, diagonally related to Zn in the periodic table, with other divalent ions. Indium supplements might replace gastric bands for managing obesity.

**Reproduction**

Figure 19 shows how the pineal gland distributes silver, Ag in 6-member serotonin rings resembling those in Figure 9. Ag porphyrin<sup>17</sup> is pink, the colour of leaf buds. Anti-cancer drugs mimic the PP<sub>i</sub> arginine complex which provides the ingredients for replicating DNA at cell division, Figure 20. As for *Motility*, retinal transfers energy stored in the porphyrin as solitons for converting phosphate, P<sub>i</sub> to pyrophosphate, PP<sub>i</sub>, Figure 21. P<sub>i</sub>’s roles for energetics, DNA synthesis and skeletal maintenance are managed separately.

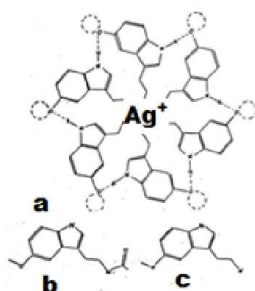

W21 Fig 19. [a] Distributing Ag from pineal [b] Melatonin [c] Serotonin



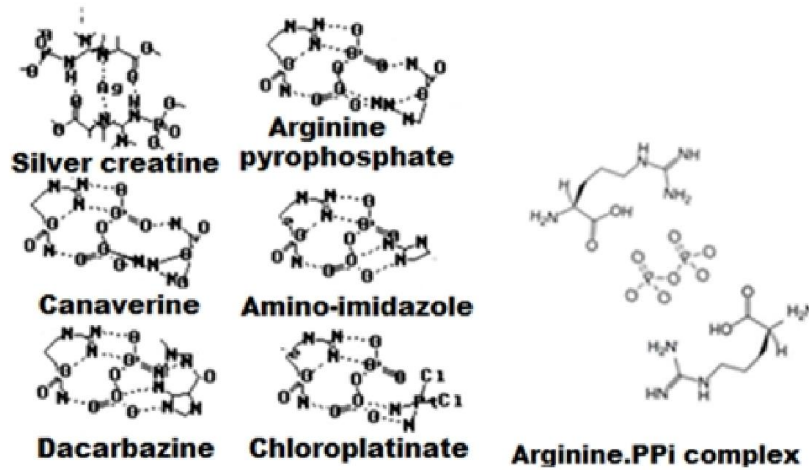

W22 Fig 20. Anti-cancer drugs mimic arginine-PP<sub>i</sub> complex

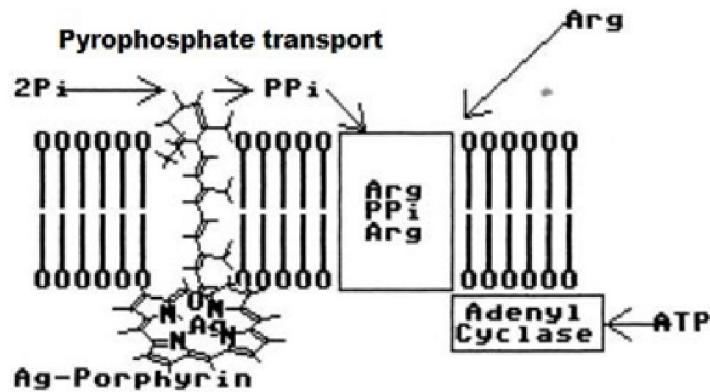

W23 Fig 21. Solitons from Ag porphyrin convert P<sub>i</sub> to PP<sub>i</sub> for arginine transport

Ag repairs tissues and regulates sleep, deficiency allows cancers to develop. Ag colloids were widely used in medicine before the advent of antibiotics. Alkaline phosphatase assays assess bone pathology.

**Water pumping**

Membrane potential prevents water diffusing through unit membranes, discrediting Mitchell’s chemiosmotic theory. The residue of saturated fat breakdown, mevalonate, is named after the herb *Valerian*, also known as *all heal*. Exchanging phospho-mevalonate with phospho-mevalonolactone transports water, Figure 22.

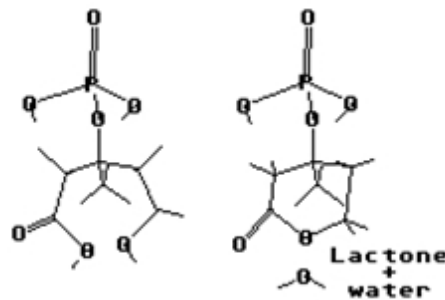

W24 Fig 22. Phospho-mevalonate & phosphomevalonolactone transport water

Manganese, Mn is cofactor for converting surplus mevalonate to cholesterol, a waste product used for synthesising steroid hormones, Figure 23.

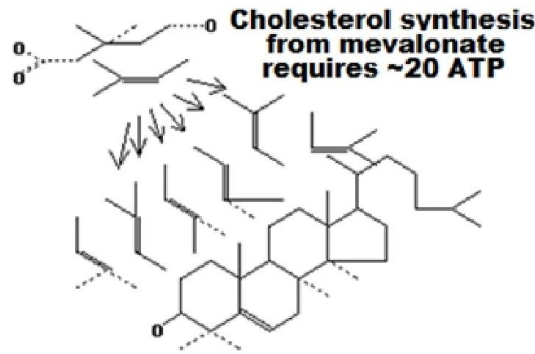

W25 Fig 23. Cholesterol synthesis

The posterior pituitary gland packs selenium, Se into oxytocin and vasopressin. At target tissues, vitamin E,  $\alpha$ -tocopherol delivers energy as solitons, see *Motility*, oxidising Se to selenite,  $SeO_3^-$  carrier for exchanging  $Ca^{++}$  with  $Mn^{++}$ .

Se deficiency is attributable to: precipitation during water purification<sup>18</sup>, displacement by sulphurous fertilizers such as superphosphate<sup>19</sup>, farming low-Se soils, food preparation and preservation using high temperatures<sup>20</sup> and poor nutrition. It causes hypertension during pregnancy, deaths from heart attacks and strokes and cancers of tissues specializing in water pumping: breast, bowel, cervix and prostate.

Breast cancer distribution correlates with surface geology<sup>21</sup>, ‘hard’ water from limestone and water percolating through volcanic rocks contain most Se, presumably deposited by early life. Sea floor Mn nodules may also reflect life’s Se-dependency. Perhaps the longevity of European royal families is attributable to their rich, high Se diets.

Se supplementation in animal husbandry<sup>22</sup> provides the best evidence for Se dependency. It’s used to protect cattle from hypertension during pregnancy, sheep from white muscle disease and pigs from heart failure *en route* to market. Precedents for augmenting diet are: limes for scurvy, I for goitre, cod liver oil for rickets and fluoridation of water supplies for tooth decay. Supplementing Se promises to prevent heart attacks and common cancers, it might prevent or treat Ebola, characterised by water loss.

**Blood pressure disorders, Figure 24, can be corrected by attention to**

- tDNA<sub>Water transport</sub> genetics.
- Saturated fat consumption.
- LDL/HDL cholesterol transport.
- Mn & cholesterol synthesis.
- Exercise and Ca levels.
- Glutathione and S metabolism.
- HgMe<sup>+</sup> competing with SeMe<sub>2</sub><sup>+</sup>.
- Se and vitamin E deficiency.

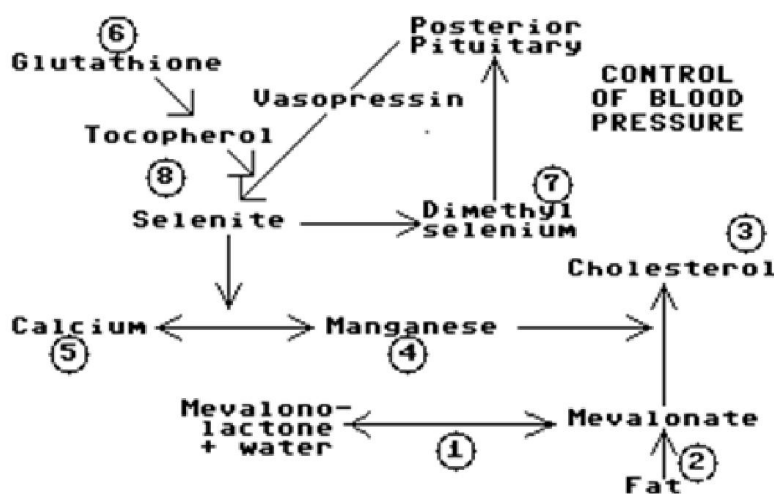

W26 Fig 24. Eight ways to regulate blood pressure

**Minion structure**

Human intelligence is usually explained with reference to binary computers and neural networks. Alan Turing asked: *Can machines think ... do well in the imitation game?* I add: *Can artificial intelligence think laterally, share compassion — offer more useful answers than 'yes|no'?* I addressed that question whilst programming an IBM 360 and Commodore PET for my first job. Using drawings of coils and spirals, molecular models and rotating the base-pairs of an uncoiled B-helix the structure emerged, Figure 25.

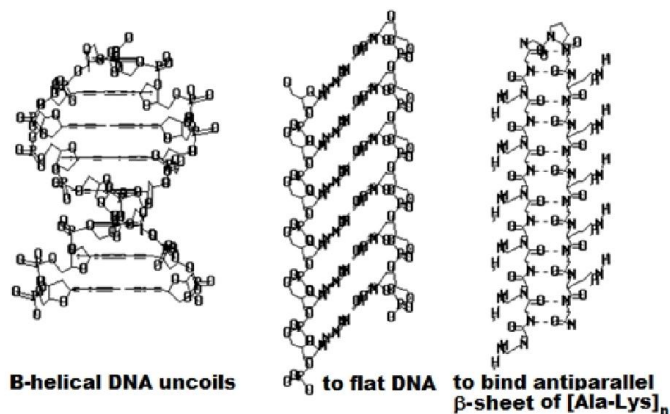

W27 Fig. 25. Uncoiled DNA binds to  $\beta$ -pleated protein sheets

I dubbed it ‘minion’, connoting mind and subservience. Minions comprise 1,701 DNA base pairs, retaining the B-helix’s base-pair spacing and overlap. Anti-parallel  $\beta$ -pleated protein sheets with alternate neutral and basic amino acids and proline forming an asymmetric U-bend hold them flat. Gramicidin S<sup>23</sup>, Figure 26, has an analogous structure. Twenty-one nine base-pair units form a coil and more protein hairpins hold nine coils together. Their super-coils pack chromosomal DNA neatly, nucleosome core particles<sup>24</sup> are probably preparative artefacts, Figure 27.

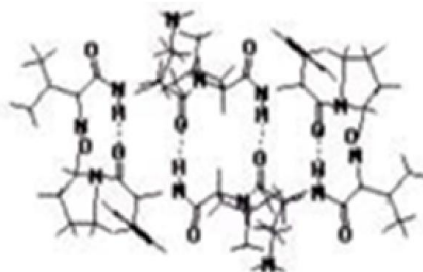

W28 Fig 26. The phenyl alanine residues in Gramicidin S are analogous to DNA bases

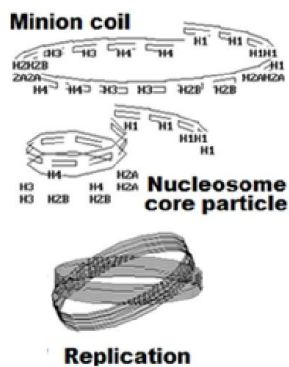

W29 Fig 27. Minion coil & nucleosome core particle compared & minions replicating

The Ala, Leu, Ile and Val residues match DNA bases C, G, A and T, mnemonic A LIve CiGAreTte, preserving DNA sequence integrity, Figure 28. Stacked minions form super-coils correctly predicting chromosome dimensions, Figure 29. Their H-bond lined tunnels, T in Figure 30, serve as molecular-scale proton accelerators.

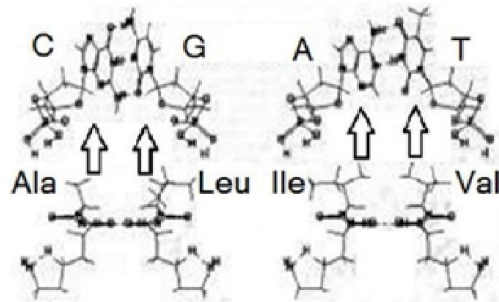

W30 Fig 28. Amino acids & DNA bases match

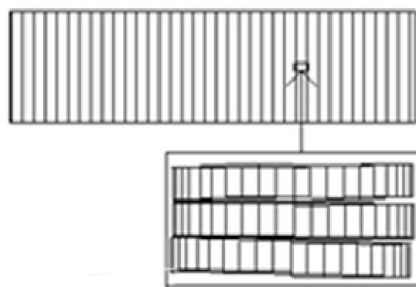

W31 Fig 29. Minions stacks pack DNA on chromosomes

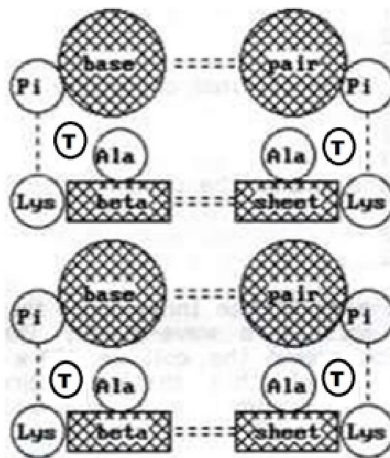

W32 Fig 30. Tunnels along minion coils

**Minion function**

Probably evolved to enable error-free DNA replication, minions have many other functions.

The H-bonds connecting DNA phosphates to amino acid  $\omega$ -amines oscillate, progressing round minion coils like rows of dominoes collapsing, Figure 31. They constitute the eighteen hands of biological clocks. The time unit,  $\tau$  taken for light to travel thrice round the fastest coil is:

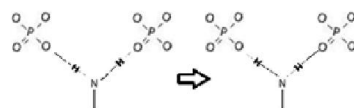

W33 Fig 31. Oscillating H-bonds accelerate protons

$$\tau = 3 * 189 * 7.37 * 10^{-10} * 3 * 10^8 \approx 1.39 * 10^{-15} \text{ seconds.}$$

where 3 reflects Dekatron™<sup>25</sup> logic, Figure 32, 189 base pairs per coil, 7.37 Å β-sheet spacing and 3 \* 10<sup>8</sup> the velocity of light. 63<sup>N</sup> τ, N = 1 to 18, calculates other coil periods, those for N = 11, 13 and 18 equate with day-length, Sun-spot cycle period and the age of the universe. Times outside the range τ to 63<sup>18</sup> τ, and mathematical zero/infinity, 0|∞ are unreal. τ is the anthropological equivalent of Planck’s constant, h. Tests of Heisenberg’s uncertainty, Einstein’s relativity and le Maitre’s big bang cosmology using particle accelerators, telescope arrays and rocketry are subject to errors. Minions are coiled abaci, introducing wrap-around counting errors according to the *Tyger equation*, describing relativity between perception and conception, Figure 33. They account for Einstein’s reference to *spooky action at a distance*.

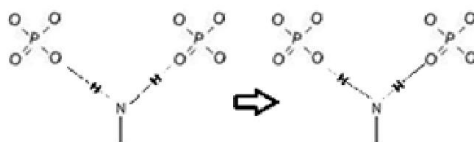

W34 Fig 32. Minions count

$$\left. \begin{aligned} \frac{d^2\theta}{dt^2} &= \frac{\pi\beta^2}{2\sqrt{e^{([1+\beta]^t \tau + [1+\beta]^{-t} \tau)}}} \\ \frac{d^2\theta}{dt^2} &= \frac{\pi\beta^2}{2\sqrt{e^{([1+\beta]^t \tau - [1+\beta]^{-t} \tau)}}} \end{aligned} \right\}$$

W35 Fig 33. Tyger relativity equation

This hyperbolic function, inspired by Blake’s: *What immortal hand or eye dare frame thy fearful symmetry?*<sup>26</sup>, distorts our perception of straight lines. The ideas that plane surfaces appear spherical, planes replace particles as fundamental entities and time’s a figment of our imagination, although counter-intuitive, are more powerful than quantum mechanics.

Protons colliding with atomic nuclei in minion tunnels have energy:

$$\frac{1}{2} p_m (c/189)^2 \approx 13,000 \text{ eV}$$

using proton mass  $p_m = 1.67 * 10^{-27}$  kg sufficient to drive fusion with nuclei of molecules stuck in the tunnel.

The ½-lives and energies of recoiling fusion products correlate with those of pulsars<sup>27</sup>, implying minion nuclear fusion produces them. DNA diffracts the γ-rays released at source and they return like boomerangs according to the *Tyger* equation. Protons accelerated along tunnels in proton-ordered water adhering to Pd crystals explain Fleischmann and Pons<sup>28</sup> reports of cold fusion, Figure 34.

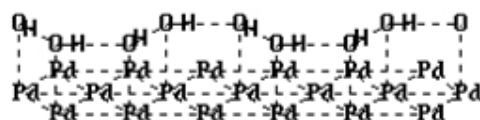

W36 Fig 34. Channels between water & palladium crystal surface

The human race carries ~10<sup>28</sup> minions, ~30 Mt of chromatin, sufficient to replenish life’s atomic constituents, H, C, N, O, S and P. Nested shells of planes reminiscent of Plato’s perfect solids reinterpret electron orbital types s, p & π and chemical bonds —, =, ≡ & ∙, Figure 35. The carbon-nitrogen cycle can be expressed in these terms, Figure 36. They also explain Mendeleev’s periodic table of the elements<sup>29</sup>. All life forms share the same atomic alphabet, trace elements’ roles as enzyme cofactors mask those for membrane transport.

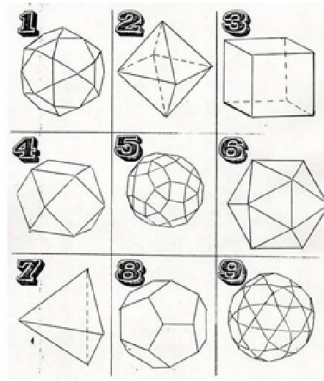

W37 Fig 35. 9 Plane combinations

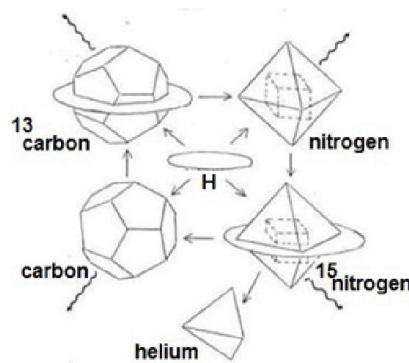

W38 Fig 36. Carbon-nitrogen cycle

The minion’s most significant role is serving as the chip in the brain, its 18 frequency bands spanning the knowable electromagnetic spectrum, are equivalent to a 103-octave piano. Table 3 lists the qualities and other properties associated with each waveband. The neural network brain model fails to allow for the nine independent, mathematically orthogonal, personality traits embracing all neurological, psychiatric and philosophical classifications.

#	QUALITY	PERIOD	COLOUR	MASS	DISCIPLINE
-9	unity	8.7 fsec	red	$m_e/7$	quantum theory
-8	justice	5.5 psec	silver	$m_p/7$	physics
-7	stability	350 psec	blue	2 base pairs	chemistry
-6	progress	22 nsec	violet	8.3 ng	computing
-5	love	1.4 $\mu$ sec	bronze	0.033 pg	biochemistry
-4	peace	87 $\mu$ sec	yellow	130 pg	genetics
-3	beauty	5.5 msec	pied	0.51 $\mu$ g	biology
-2	truth	350 msec	gold	2 mg	engineering
-1	goodness	22 sec	green	8.1 g	psychology
+1	goodness	23 min	green	32 kg	psychiatry
+2	truth	1 day*	gold	130 ton	management
+3	beauty	9 wk	pied	0.5 Mton	sociology
+4	peace	11 yr*	yellow	2000 Mton	politics
+5	love	685 yr	bronze	8 Gton	history
+6	progress	43,000 yr	violet	31 Pton	archaeology
+7	stability	2.7 Myr	blue	1.8 Moons	palaeontology
+8	justice	170 Myr	silver	84 Earths	astronomy
+9	unity	11 Byr*	red	Sun	cosmology

where the numbers label inner and outer coil surfaces; periods =  $63^N \tau$ , their units  $f = 10^{-15}$ ,  $p = 10^{-12}$ ,  $n = 10^{-9}$ ,  $\mu = 10^{-6}$ ,  $m = 10^{-3}$ ,  $M = 10^6$ ,  $B = 10^9$ ,  $G = 10^{12}$  and  $P = 10^{15}$ ; colours feature in metaphors, advertisements, national flags and political logos; ratio between masses =  $63^2$ ,  $m_e =$  electron mass,  $m_p =$  proton mass (an ant carries many times its weight, elephants can’t, suggesting the square root of mass,  $\mu = \sqrt{M}$  is more appropriate for measuring weight, making Einstein’s  $E = Mc^2$  more symmetric:  $E = \mu^2 c^2$ . 5000 words, 4 tables, 35 diagrams

W39 Table 3. Mental associations with minion coils

W6 Table 1. Nine independent biological pathways

#	SYSTEM	TISSUE	CARRIER	SUBSTRATE	PATHOLOGY
1	motility	muscle	Ca <sup>++</sup>   Mg <sup>++</sup>	SO <sub>3</sub> <sup>=</sup>	spasticity
2	sensitivity	nerve	Na <sup>+</sup>   K <sup>+</sup>	catecholamines	depression
3	excretion	kidney	Mn <sup>++</sup>	salt	kidney failure
4	respiration	lung	Γ <sup>+</sup>	O <sub>2</sub> .H <sub>2</sub> O	bipolar
5	metabolism	liver	Cu <sup>++</sup>	amino-acids	growth defects
6	rigidity	bone	SiF <sub>6</sub> <sup>=</sup>   AlF <sub>6</sub> <sup>=</sup>	apatite	Alzheimer's
7	assimilation	gut	Zn <sup>++</sup>	β-Dglucose	diabetes
8	reproduction	gonads	Ag <sup>+</sup> & arginine	pyrophosphate	cancer
9	water-pumping	heart	Mn <sup>++</sup> & SeO <sub>3</sub> <sup>=</sup>	water	heart disease

W5 Fig 5. Periodic table of the elements showing essential, toxic and unused elements

W16

H																	He
Li	Be											B	C	N	O	F	Ne
Na	Mg											Al	Si	P	S	Cl	Ar
K	Ca	Sc	Ti	V	Cr	Mn	Fe	Co	Ni	Cu	Zn	Ga	Ge	As	Se	Br	Kr
Rb	Sr	Y	Zr	Nb	Mo	Tc	Ru	Rh	Pd	Ag	Cd	In	Sn	Sb	Te	I	Xe
Cs	Ba	La	Hf	Ta	W	Re	Os	Ir	Pt	Au	Hg	Tl	Pb	Bi	Po	At	Rn
Fr	Rh	Ac	Rf	Db	Sg	Bh	Hs	Mt	Ds	Rg	Cn						
				Ess	Tox	n/u											

Table 2 Hooks determine morphology

HOOKS	MORPHOLOGY
0	Undifferentiated 'pluripototent' stem cells
1	Eggs, sperm and immune system leukocytes
2	Spirogyra filaments
3	Sponge sheets
4	Bi-layered worms
5	Liver and other organs use combinations of up to 5 hooks
6	6-hooked cells, allowing tumour and cancer growth

W39 Table 3. Mental associations with minion coils

#	QUALITY	PERIOD	COLOUR	MASS	DISCIPLINE
-9	unity	8.7 fsec	red	m <sub>e</sub> /7	quantum theory
-8	justice	5.5 psec	silver	m <sub>p</sub> /7	physics
-7	stability	350 psec	blue	2 base pairs	chemistry
-6	progress	22 nsec	violet	8.3 ng	computing
-5	love	1.4 μsec	bronze	0.033 pg	biochemistry
-4	peace	87 μsec	yellow	130 pg	genetics
-3	beauty	5.5 msec	pie	0.51 μg	biology
-2	truth	350 msec	gold	2 mg	engineering
-1	goodness	22 sec	green	8.1 g	psychology
+1	goodness	23 min	green	32 kg	psychiatry
+2	truth	1 day*	gold	130 ton	management
+3	beauty	9 wk	pie	0.5 Mton	sociology
+4	peace	11 yr*	yellow	2000 Mton	politics
+5	love	685 yr	bronze	8 Gton	history
+6	progress	43,000 yr	violet	31 Pton	archaeology
+7	stability	2.7 Myr	blue	1.8 Moons	palaeontology
+8	justice	170 Myr	silver	84 Earths	astronomy
+9	unity	11 Byr*	red	Sun	Cosmology

where the numbers label inner and outer coil surfaces; periods = 63<sup>N</sup>τ, their units f = 10<sup>-15</sup>, p = 10<sup>-12</sup>, n = 10<sup>-9</sup>, μ = 10<sup>-6</sup>, m = 10<sup>-3</sup>, M = 10<sup>6</sup>, B = 10<sup>9</sup>, G = 10<sup>12</sup> and P = 10<sup>15</sup>; colours feature in metaphors, advertisements, national flags and political logos; ratio between masses = 63<sup>2</sup>, m<sub>e</sub> = electron mass, m<sub>p</sub> = proton mass (an ant carries many times its weight, elephants can't, suggesting the square root of mass, μ = √M is more appropriate for measuring weight, making Einstein's E = Mc<sup>2</sup> more symmetric: E = μ<sup>2</sup>c<sup>2</sup>).

Natural intelligence has evolved to excel over computer technology. Comparing large numbers using ratios, percentages, exponents and logarithms is consistent with minion logic. The 1.8 M minions in any human cell nucleus could store Shakespeare's works, the Bible and Koran using 18 letter words and a 63-character alphabet. Minions within the same nucleus or in cells connected by nerve fibres resonate when they store similar words, accounting for memory recall. Nerve fibres serve as optic cables, their synaptic junctions act as filters. Partial matches suggest compromise. Transposing between minion coils, equivalent to changing key in music, enables lateral thinking.

Information indexed in eighteen minion categories would improve search and retrieval. Computer systems modelled on them could compensate for the personality biases astrologers, psychologists and philosophers study. Peace negotiations, educational curricula and management decisions could be improved and research on exceptions and action on new ideas encouraged.

## Calculations

Cubic and tetragonal ices' molecular coordinates can be calculated using:

H-bond length	$h = 1.75 \text{ \AA}$	Dielectric constant	$\epsilon = 3.1$
OH-bond length	$b = 1.01 \text{ \AA}$	Space dielectric	$\epsilon_0 = 8.85 * 10^{-12}$
Tetrahedral angle	$\theta_a = 104.5^\circ$	Planck's constant	$h = 6.63 * 10^{-34}$
H-O-H bond angle	$\theta_b = 109.5^\circ$	Avogadro number	$N = 6.02 * 10^{23}$
Charge cloud angle	$\theta_c = 120^\circ$	Velocity of light	$c = 3 * 10^8$
Dipole moment	$\mu = 1.27 * 10^{-29}$		

Ice Ic:

$$\Delta x = \Delta y = (b + h) \sin(\frac{1}{2} \theta_a) = 2.26 \text{ \AA}$$

$$\Delta z = (b + h) \cos(\frac{1}{2} \theta_a) = 1.6 \text{ \AA}$$

Ice It:

$$\Delta x = \Delta y = b \sin(\frac{1}{2} \theta_b) + h \sin(\frac{1}{2} \theta_c) = 2.32 \text{ \AA}$$

$$\Delta z = b \cos(\frac{1}{2} \theta_b) + h \cos(\frac{1}{2} \theta_c) = 1.5 \text{ \AA}$$

Estimating the energy change per molecule, E when ice It crystals collapse involves the convergence of parallel dipoles  $r$  apart, displaced axially by  $z$  and laterally by  $x$  and  $y$ , in a ferroelectric transition:

$$E = \frac{\mu^2}{4\pi\epsilon\epsilon_0 r^3} = \frac{(1.27 * 10^{-29})^2}{4\pi * 3.1 * 8.85 * 10^{-12} * r^3}$$

$\Sigma E \approx 22.3 \text{ kJ/mol}$ , approximating ATP's phosphodiester bond energy,  $P_i \sim P_i$  with wavelength  $\lambda = h * c * N / \Sigma E$ :

$$\lambda = 6.63 * 10^{-34} * 3 * 10^8 * 6.02 * 10^{23} / 22.3 * 10^4 = 5.37 \mu$$

NB  $\lambda \approx 4\mu$  makes successful predictions, suggesting this result needs expert review.

## Conclusion

Basic things have to be simple. For further information, please search my webpage, [www.scienceuncoiled.co.uk](http://www.scienceuncoiled.co.uk) or the internet using 'michaeldeans'. It's open to any individual or organisation to verify, develop and implement my ideas. Results should be made available to the public without undue profit, fostering peaceful, loving and progressive life on Earth. Eventually, goodness, truth, beauty, peace, love, progress, stability, justice and unity will be equally respected. Max Ehrmann wrote:

## Desiderata

Go placidly amid the noise and haste, and remember what peace there may be in silence. As far as possible without surrender be on good terms with all persons. Speak your truth quietly and clearly; and listen to others, even the dull and ignorant; they too have their story. Avoid loud and aggressive persons, they are vexations to the spirit. If you compare yourself with others, you may become vain and bitter; for always there will be greater and lesser persons than yourself.

Enjoy your achievements as well as your plans. Keep interested in your career, however humble; it is a real possession in the changing fortunes of time. Exercise caution in your business affairs; for the world is full of trickery. But let this not blind you to what virtue there is; many persons strive for high ideals; and everywhere life is full of heroism. Be yourself. Especially, do not feign affection. Neither be critical about love; for in the face of all aridity and disenchantment it is as perennial as the grass.

Take kindly the counsel of the years, gracefully surrendering the things of youth. Nurture strength of spirit to shield you in sudden misfortune. But do not distress yourself with imaginings. Many fears are born of fatigue and loneliness. Beyond a wholesome discipline, be gentle with yourself. You are a child of the universe, no less than the trees and the stars; you have a right to be here. And whether or not it is clear to you, no doubt the universe is unfolding as it should. Therefore be at peace with God, whatever you conceive Him to be, and whatever your labours and aspirations, in the



noisy confusion of life keep peace with your soul. With all its sham, drudgery and broken dreams, it is still a beautiful world. Be careful. Strive to be happy.

## REFERENCES

\* Comments and suggestions addressed to author Michael T Deans by emailing michaeltdeans@gmail.com will receive attention if possible.

- Blake, W. 1970. *The Tyger, Songs of experience*. OUP, London.
- Blundell, T. L., Cutfield, J. F., Cutfield, S. M., Dodson, E. J., Dodson, G. G., Hodgkin, D. C., Mercola, D. A. and Vijayan, M. 1971. Atomic positions in rhombohedral 2-zinc insulin crystals. *Nature* 231, 506–511.
- Chen, Y. and Wallace, B. A. 1996. Binding of alkaline cations to the double-helical form of gramicidin. *Biophysical J.*, 71 163-170.
- Connock, M., Grung, T., Freeman, K., Johnson, S., Ngianga-Bakwin, K., Grove, A., Gurung, B., Morrow, S., Stranges, S. and Clarke, I. 2013. PLOS.
- Divers, T. J., Mohammed, H. O., Hintz, H.F. and de Lahunta, A. 2006. Evaluation of the risk of motor neuron disease in horses fed a diet low in vitamin E and high in copper and iron. *American Journal of Veterinary Research*, 5 24-26.
- Durot, S., Flamigni, L., Taesch, J., Dang, T. T., Heitz, V. and Ventura, B. 2014. Synthesis and Solution Studies of Silver(I)-Assembled Porphyrin Coordination Cages. *Chemistry - European J.*, 20, 9979-9990.
- Espinosa, M. G. <http://www.chemguide.co.uk/physical/equilibria/haber.html> (checked 10 July 2015)
- Fleischmann, M., Pons, S. and Hawkins, M. 1989. Electrochemically induced nuclear fusion of deuterium. *J Electroanal Chem* 261 301–308.
- Harp, J. M. et al. 1996. X-ray diffraction analysis of crystals containing twofold symmetric nucleosome core particles. *Acta Crystallogr D Biol Crystallogr.*, 52 2 283-288.
- Hewish, A. 1975. Pulsars and high density physics. *Science*. 188 1079–1083.
- Homepage of Deans, M. T. <http://www.scienceuncoiled.co.uk> (checked 10 July 2015)
- Hough, L. and Emsley, J. 1986. The shape of sweeteners to come. *New Scientist* 1509
- Kulldorff, M., Feuer, E. J., Miller, B. A. and Freedman, L. S. 1997. Breast cancer clusters in the northeast United States: a geographic analysis. *Am. J. Epidemiol*, 146 161-170.
- Likens, G. E. et al. 1979. Acid rain. *Scientific American*. 241, 43 – 51.
- Luger, K., Mader, A. W., Richmond, R. K., Sargent, D. F. and Richmond, T. J. 1997. Crystal structure of the nucleosome core particle at 2.8 Å resolution. *Nature* 389, 251-260
- Lyons, G.H., Judson, G. J., Ortiz-Monasterio, I., Genc, Y., Stangoulis, J. C. R. and Graham, R. D. 2005. Selenium in Australia: Selenium status and biofortification of wheat for better health. *Journal of Trace Elements in Medicine and Biology*, 19, 75-82.
- MacDougall, M. A. 1965. Using the cold-cathode tube: part 1. *Electronics*. 78.
- Margioris, A. N. and Tsatsanis, C. 2015. ACTH Action on the Adrenal, in Chrousos G. *Adrenal physiology and diseases*. <http://www.endotext.org> (checked 10 July 2015)
- Murray, B.J., Knopf, D. A. and Bertram, A. K. 2005. Formation of ice under conditions relevant to the Earth's atmosphere. *Nature*, 7030, 202-205.
- Pauling, L. 1935. The structure and entropy of ice and of other crystals with some randomness of atomic arrangement. *JACS* 57, 2680-2584.
- Pauling, L. 1970. *Vitamin C and the Common Cold*. Freeman.
- Prusiner, S. B. 1998. Prions. *PNAS* 95, 13363–13383.
- Scerri, E. R. 2007. *The periodic table: its story and its significance*. OUP.
- Sinkala, Z. 2006. Soliton/exciton transport in proteins. *J. Theor Biol.*, 241, 919–927.
- Smedley, P. L. 2010. A survey of the inorganic chemistry of bottled mineral waters from the British Isles. *Applied Geochemistry* 25 1872-1888.
- Spears, J. W. 2003. Trace Mineral Bioavailability in Ruminants. *J Nutrition* 133, 15065-15095.
- Sussman, J. L. and Kim, S. 1976. Three dimensional structure of a transfer RNA in two crystal forms. *Science*, 192, 853-858.
- Sutcliffe, P., Uruakpa, F. O., Ismond, M. A. H. and Akobundu, E. N. T. 2002. Colostrum and its benefits: a review. *Nutrition Research* 22, 755-767.
- Wisniewski, T. 2012. Active immunotherapy for Alzheimer's disease. *The Lancet Neurology*, 11, 571 – 572.
- Zhao, H.X., Kong, X.J., Li, H., Jin, Y.C., Long, L.S., Zeng, X. C., Huang, R.B. and Zheng, L.S. 2011. Transition from one-dimensional water to ferroelectric ice within a supramolecular architecture. 108 3481-3486.

\*\*\*\*\*